

SKYRC

v. 63

Instruction Manual

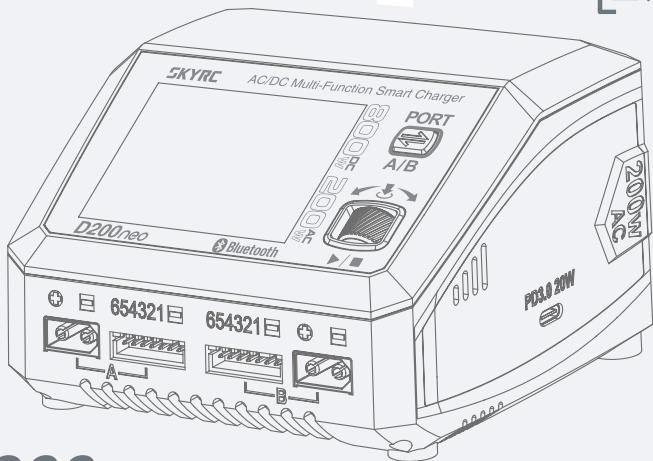

D200neo

AC/DC Multi-Function Smart Charger

SK-100196

Contents

Introduction	03
Warning	03
Getting to know D200neo	04
Specifications	05
Standard Battery Parameters	06
Power and Battery Connection	07
Program Flow Chart	08
Battery Operations Matrix	10
Lithium Battery Program (LiPo/LiFe/Lilon/LiHV)	11
Parallel Charge (LiPo/LiFe/Lilon/LiHV)	12
NiMH/NiCd Battery Program	13
Pb Lead-Acid Battery Program	14
External Discharge	15
Working with Charger Master	16
Battery Performance Analyzer	17
App Control with SkyRC	18
DC Power	19
PD/QC3.0 Output	20
BumpGo with NFC Enabled	21
Firmware Upgrade	23
Errors Explained	24
Charge Settings	25
System Settings	26
In The Box	28
Optional Parts	28
Conformity Declaration	29
Warranty and Service	30

Introduction

Thank you for choosing SkyRC D200neo AC/DC Multi-Function Smart Charger!

D200neo features independent dual ports and supports most batteries used in the RC industry. As a dual-input charger, it is versatile enough for various charging scenarios. In addition to inheriting the well-crafted interface and powerful functions of the T1000, we've added SkyRC App control, Charger Master control for Windows/macOS, and PD/QC3.0 fast charging. This makes D200neo adaptable to different users' needs across diverse situations.













The new design and upgraded scroll button make operation more convenient and user-friendly.

Please read the Operating Instructions and Safety Notes carefully before use.

Warning

D200neo is not intended for use by individuals with reduced physical, sensory, or cognitive abilities, or by those lacking experience and knowledge with batteries, unless under the supervision or guidance of a responsible person.

Failure to use this product properly and follow the warnings below may result in malfunction, electrical issues, overheating, fire, and could lead to injury or property damage.

-  Never leave charging batteries unattended during use.
-  Never charge batteries overnight.
-  Never attempt to charge dead, damaged, or wet battery packs.
-  Never attempt to charge a battery pack containing different types of batteries.
-  Never charge batteries in extremely hot or cold places or place in direct sunlight.
-  Never charge a battery if the cable has been pinched or shorted.
-  Never connect the charger if the power cord has been pinched or shorted.
-  Never attempt to dismantle the charger or use a damaged charger.
-  Never attach your charger to both a PD and a DC power source at the same time.
-  Always use the charger with the correct charging and discharging program.
-  Always use only rechargeable batteries designed for use with this type of charger.
-  Never use the charger on car seats, carpets, or similar surfaces.
-  Always operate the charger away from flammable and explosive materials.

SkyRC Technology Co., Ltd. accepts no liability in such cases

Getting to know D200neo

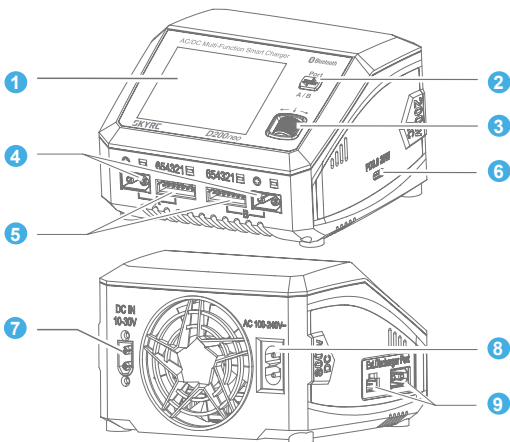

Interface:

1 LCD Display

2 Port Button

Switch between Ports A and B;
Short-press to exit System Settings;

3 Scroll Button

Short-press to enter the menu or confirm a setting;
Scroll to select a menu or set parameters;
Press and hold for five seconds on the main interface to access System Settings;

Ports:

4 XT60 Output

5 Balance Port

6 USB-C PD/QC3.0 Output Port

7 DC Input

8 AC Input

9 External Discharge Port

Specifications

Model		D200neo
Input Voltage	AC	Max. 2.5A @ 100V Max. 1.2A @ 220V
	DC	Max. 35A (Max. 17.5A per single channel)
Input Current		30.0-35.0A
Charge Power	AC	Max. 200W ($\pm 10\%$)
	DC	Max. 800W (400W X 2)
Discharge Power	Main port	10W($\pm 20\%$)
	Balance port	Max. 37W
	External discharge	Max. 350W (0.1A-40A)
Charge Current	LiPo/LiFe/LiIon/LiHV/NiMH/ NiCd/Pb	0.1A-0.5A ($\pm 0.3A$); 0.6A-20A ($\pm 10\%$)
	Parallel	20-35A ($\pm 5\%$)
Discharge Current	LiPo/LiFe/LiIon/LiHV/NiMH/ NiCd/Pb	0.1-2A ($\pm 10\%$)
	External Discharge	0.1-40.0A
Balance Current	LiPo/LiFe/LiIon/LiHV	Max. 1.5A
Battery Types	LiPo/LiFe/LiIon/LiHV	1-6S
	NiMH/NiCd	4-15S
	Pb	3S/6S/12S
Working Modes	LiPo/LiFe/LiIon/LiHV	Balance CHG, Charge, Storage, Discharge, Parallel
	NiMH/NiCd	Charge, Re-Peak, CYCLE_C_D, CYCLE_D_C, Discharge
	Pb	Normal, AGM Charge, Cold Charge, Discharge

Specifications

DC Power Supply	Voltage	5-27V ($\pm 0.5V$)
	Current	1-15A ($\pm 10\%$)
USB Type-C Output	QC3.0	5V \leq 3A, 9V \leq 2A, 12V \leq 1.5A 18W
	PD	5V \leq 3A, 9V \leq 2.2A, 12V \leq 1.67A 20W
Working Environment	Temperature	0°C/32°F ~ 40°C/104°F
	Humidity	5%~75%
Storage Environment	Temperature	-10°C/14°F ~ 70°C/158°F
	Humidit	5%~75%
Size	116*110*79mm	
Weight	602g	



Standard Battery Parameters

	LiPo	Lilon	LiFe	LiHV	NiMH	NiCd	Pb
Nominal Voltage	3.7V/cell	3.6V/cell	3.3V/cell	3.8V/cell	1.2V/cell	1.2V/cell	2.0V/cell
Max. Charge Voltage	4.2V/cell	4.1V/cell	3.65V/cell	4.35V/cell	1.5V/cell	1.5V/cell	2.4V/cell
Storage Voltage	3.8V/cell	3.7V/cell	3.3V/cell	3.85V/cell	N/A	N/A	N/A
Allowable Fast Charge Current	$\leq 1C$	$\leq 1C$	$\leq 4C$	$\leq 1C$	1-2C	1-2C	$\leq 0.4C$
Min. Discharge Voltage	3.0-3.4V/cell	2.9-3.3V/cell	2.6-3.0V/cell	3.1-3.5V/cell	0.6-1.0V/cell	0.6-1.0V/cell	1.8V~2.0V/cell

Select the correct operating procedure based on the battery parameters.

Incorrect settings could lead to battery damage, fire, or even explosion.

Power and Battery Connection

1. Connecting to Power Source

D200neo supports AC and DC dual input. The input voltages are:

DC: 10-30V

Connect to a compatible DC power source.

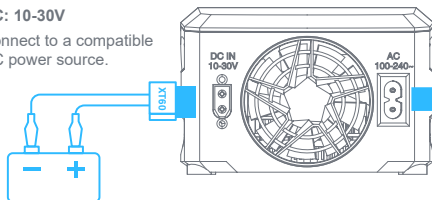

AC: 100-240V

Connect to a compatible AC power source.



2. Connecting the battery



WARNING!

To avoid short circuits, always power the charger first through the DC or AC port at the back, then connect the battery to the Charge Port at the front. When disconnecting, reverse the sequence.

Lithium Battery Connection with Balance Adapter

For safety reasons, it is highly recommended to charge Lithium batteries (LiPo, Li-ion, LiFe, and LiHV) using **Balance CHG mode**, unless the battery lacks a balance wire.

Ensure that the balance wire is connected to the charger, with the black wire aligned with the negative marking. **Check the polarity to ensure the correct connection!**

NiMH/NiCd or Pb Battery Connection

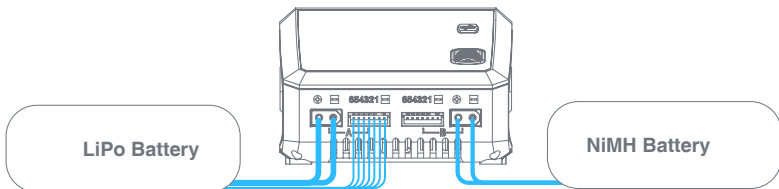

Program Flow Chart

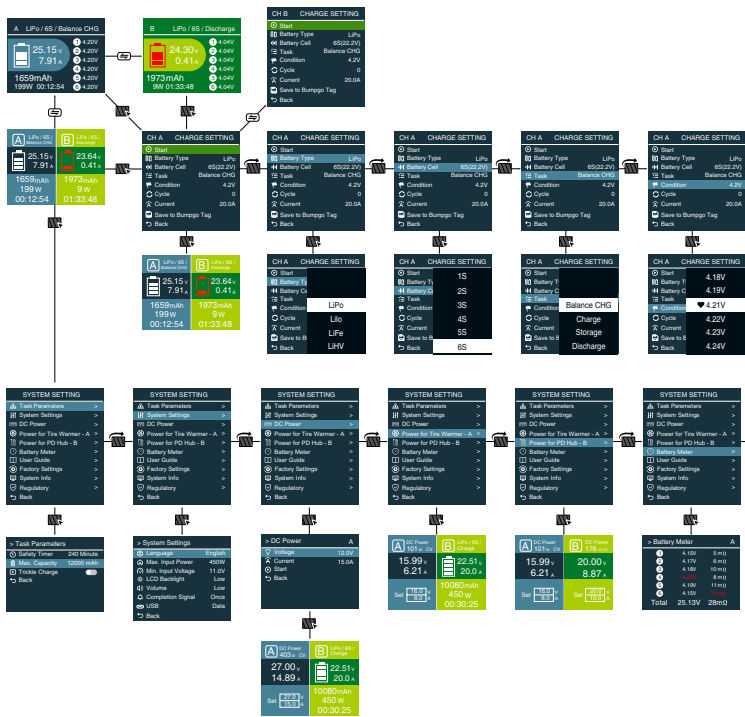

Program Flow Chart

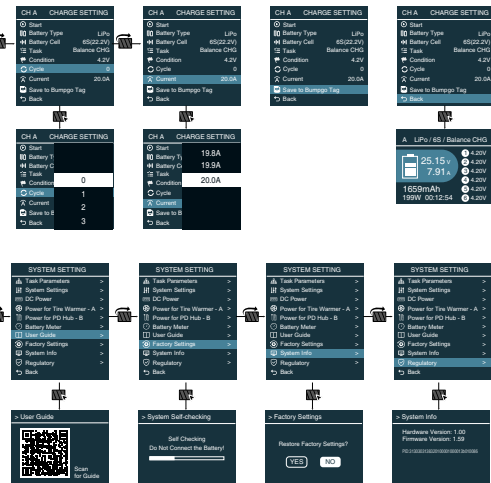
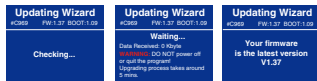

Note: The flow chart uses one port as an example, as the process for Port A and Port B is identical.



Battery Operations Matrix

Type	Working Mode	Description
LiPo Lilon LiFe LiHV	Balance CHG	This mode is to balance charge the lithium battery according to the user-defined charging rate. It ensures each cell of the battery is balanced.
	Charge	This mode charges the lithium battery based on the selected charging rate.
	Storage	This mode stores the battery via charging or discharging its voltage to a specific storage value.
	Discharge	This mode is to discharge the lithium battery based on the selected discharging rate.
	Parallel	This mode is to parallel charge the battery with a higher charge rate of up to 35A.
NiMH NiCd	Charge	This mode charges the NiMH/NiCd battery based on the selected charging rate.
	Re-Peak	In Re-Peak mode, the charger automatically peaks the battery twice in a row. This helps ensure the NiMH/NiCd battery is fully charged.
	Cycle_C_D	A cyclic and continuous process of 1 to 3 charge > discharge cycles can be used to refresh and restore the performance of NiMH/NiCd batteries.
	Cycle_D_C	1 to 3 cyclic and continuous processes of discharge>charge is operable for refreshing and restoring the performance of NiMH/NiCd batteries.
	Discharge	This mode is to discharge the NiMH/NiCd battery based on the selected discharging rate.
Pb	Normal	This mode charges the Pb battery based on the selected charging rate.
	AGM Charge	This mode charges the AGM battery based on the selected charging rate.
	Cold Charge	This mode charges the Pb battery under a low temperature based on the selected charging rate.
	Reverse CHG	This mode is to discharge the Pb battery based on the selected discharging rate.

Lithium Battery Program

(LiPo/LiFe/Lilon/LiHV)



Scan or Click to Watch

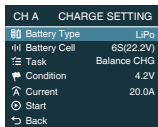

ENTER Charge Setting

On the main interface, press the scroll button to enter CHARGE SETTING.

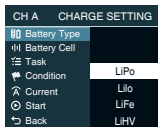

Battery Type Select

Press scroll button to call out the Battery Type menu, and scroll to select LiPo.

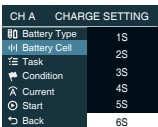

Battery Cell Select

Scroll to Battery Cell, call out the menu and scroll to select the correct battery cells.

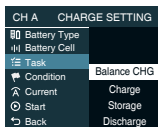

Task Select

Scroll to Task, call out the menu and scroll to select the working mode.

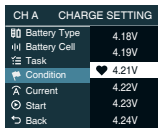

Condition Select

Scroll to Condition, call out the menu and set the delta voltage.

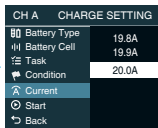

Charge/Discharge Current Select

Scroll to Charge/Discharge Current, call out the menu and scroll to select the working current.

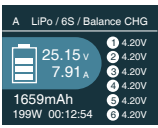

Start

Press scroll button to confirm and initiate the program.

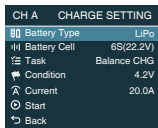

Stop

Press scroll button to stop the program.

! Do not connect the battery before turning on the charger!

Parallel Charge

(LiPo/LiFe/Lilon/LiHV)

- Parallel Mode is available only for lithium batteries and cannot be used with other battery types.
 - To avoid short circuits, always connect the charge leads to the charger first, then to the battery. When disconnecting, reverse the sequence.
1. Select the correct battery type (LiPo/LiFe/Lilon/LiHV).
 2. Choose Parallel Charge mode.
 3. Set the charging current (20-35A).
 4. Start the program after completing the setup.

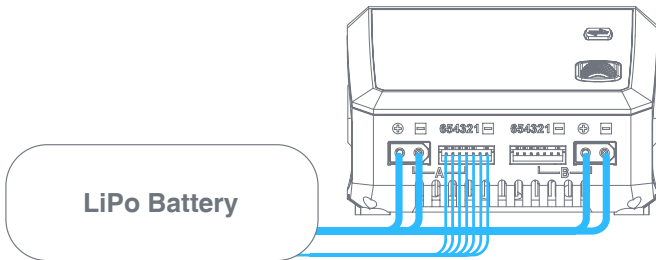

Note:

- Ensure that AC and DC power are not connected simultaneously.
- For a single port, the charging power is 200W; with dual ports, the charging power is intelligently distributed.
- Do not connect the battery before powering on the charger.
- The parallel charge cable is sold separately.

NiMH/NiCd Battery Program



Scan or Click to Watch

CH A	CHARGE SETTING
Battery Type	NiMH
Battery Cell	6S(7.2V)
Task	Charge
Condition	-6ΔmV
Charge Current	3.0A
Temp Cut-off	50°C
Start	
Back	

ENTER Charge Setting

On the main interface, press the scroll button to enter CHARGE SETTING.

CH A	CHARGE SETTING
Battery Type	Lilo
Battery Cell	LiFe
Task	LiHV
Condition	
Charge Current	NiMH
Temp Cut-off	NiCd
Start	PB
Back	

Battery Type Select

Press scroll button to call out the Battery Type menu, and scroll to select NiMH.

CH A	CHARGE SETTING
Battery Type	3S
Battery Cell	4S
Task	5S
Condition	
Charge Current	6S
Temp Cut-off	7S
Start	8S
Back	9S

Battery Cell Select

Scroll to Battery Cell, call out the menu and scroll to select the correct battery cells.

CH A	CHARGE SETTING
Battery Type	
Battery Cell	
Task	Charge
Condition	
Charge Current	Re-Peak
Temp Cut-off	CYCLE_C_D
Start	CYCLE_D_C
Back	

Task Select

Scroll to Task, call out the menu and scroll to select the working mode.

CH A	CHARGE SETTING
Battery Type	-3mV
Battery Cell	-4mV
Task	-5mV
Condition	-5mV
Charge Current	-8mV
Temp Cut-off	-7mV
Start	-8mV
Back	-9mV

Condition Select

Scroll to Condition, call out the menu and set the delta voltage.

CH A	CHARGE SETTING
Battery Type	2.7A
Battery Cell	2.8A
Task	2.9A
Condition	
Charge Current	3.0A
Temp Cut-off	3.1A
Start	3.2A
Back	3.3A

Charge/Discharge Current Select

Scroll to Charge/Discharge Current, call out the menu and scroll to select the working current.

CH A	CHARGE SETTING
Battery Type	NiMH
Battery Cell	6S(7.2V)
Task	Charge
Condition	-6ΔmV
Charge Current	3.0A
Temp Cut-off	50°C
Start	
Back	

Start

Press scroll button to confirm and initiate the program.

CH A	CHARGE SETTING
Battery Type	NiMH
Battery Cell	6S(7.2V)
Task	Charge
Condition	-6ΔmV
Charge Current	3.0A
Temp Cut-off	50°C
Start	
Back	

Stop

Press scroll button to stop the program.

Pb Lead-Acid Battery Program



Scan or Click to Watch

CH A CHARGE SETTING	
Battery Type	PB
Battery Cell	6S(12.0V)
Task	AGM Charge
Condition	2.45V
Current	5.0A
Start	
Back	

ENTER Charge Setting

On the main interface, press the scroll button to enter CHARGE SETTING.

CH A CHARGE SETTING	
Battery Type	Lilo
Battery Cell	LiFe
Task	LiHV
Condition	
Current	NIMH
Start	NiCd
Back	PB

Battery Type Select

Press scroll button to call out the Battery Type menu, and scroll to select PB.

CH A CHARGE SETTING	
Battery Type	
Battery Cell	
Task	
Condition	3S
Current	6S
Start	12S
Back	

Battery Cell Select

Scroll to Battery Cell, call out the menu and scroll to select the correct battery cells.

CH A CHARGE SETTING	
Battery Type	
Battery Cell	
Task	Normal
Condition	AGM Charge
Current	Cold Charge
Start	Discharge
Back	

Task Select

Scroll to Task, call out the menu and scroll to select the working mode.

CH A CHARGE SETTING	
Battery Type	
Battery Cell	
Task	
Condition	1.80V
Current	1.90V
Start	2.00V
Back	

Condition Select

Scroll to Condition, call out the menu and set the delta voltage.

CH A CHARGE SETTING	
Battery Type	4.7A
Battery Cell	4.8A
Task	4.9A
Condition	5.0A
Current	5.1A
Start	5.2A
Back	

Charge/Discharge Current Select

Scroll to Charge/Discharge Current, call out the menu and scroll to select the working current.

CH A CHARGE SETTING	
Battery Type	PB
Battery Cell	6S(12.0V)
Task	AGM Charge
Condition	2.45V
Current	5.0A
Start	
Back	

Start

Press scroll button to confirm and initiate the program.

CH A CHARGE SETTING	
Battery Type	PB
Battery Cell	6S(12.0V)
Task	AGM Charge
Condition	2.45V
Current	5.0A
Start	
Back	

Stop

Press scroll button to stop the program.

External Discharge

D200neo supports external discharge, reaching up to 40A when connected to the BD350 discharger.

1. Once the power supply is connected, D200neo powers up and enters the main interface automatically;
2. Connect the BD350 discharger to D200neo;
3. Connect the battery to Port A on D200neo;
4. Select the battery type, number of cells, discharge program, cut-off voltage, and discharge current;
5. Start the program once the settings are configured.

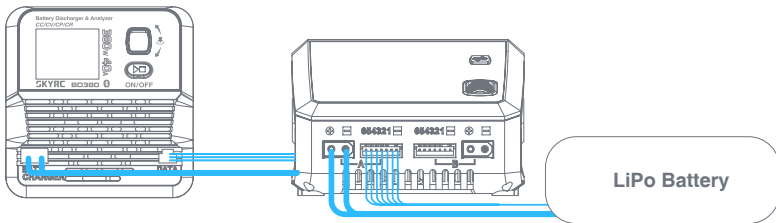

[Scan or Click to Watch](#)

Note:

- The BD350 discharger is not included and must be purchased separately;
- External discharge is available only on Port A.

Working with Charger Master

D200neo supports charging and discharging through a computer on both Windows and macOS. Various parameters such as charge time, capacity, current, and voltage can be visually displayed in curves.

1. Download the latest **Charger Master** software onto your desktop. Unzip and open it after downloading.
2. Power on your D200neo.
3. Connect the D200neo to your computer using a USB Type-C cable. (It is recommended to select the "Data" function under the USB menu in System Settings before connecting to the PC.)
4. In **Charger Master**, select the **Charge** option at the top left.
5. Set the parameters for the corresponding ports and start the program after setting.



[Scan or Click to Download](#)

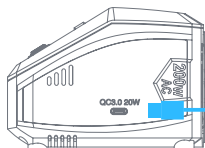

Battery Performance Analyzer

When connected to the BD350 discharger, D200neo can analyze battery performance, helping users select more suitable batteries for RC competitions and improve their results.

1. Launch Charger Master and select Battery Analyzer from the top left.
2. Specify the battery type, discharge current, cut-off voltage, and other parameters.
3. Click New Test to start the first test after configuring the settings.
4. Once the first test is complete, click Append Test to start the second test. Repeat for further tests.

Up to ten groups of test data are visualized as curves, providing clear, at-a-glance insights for RC players.

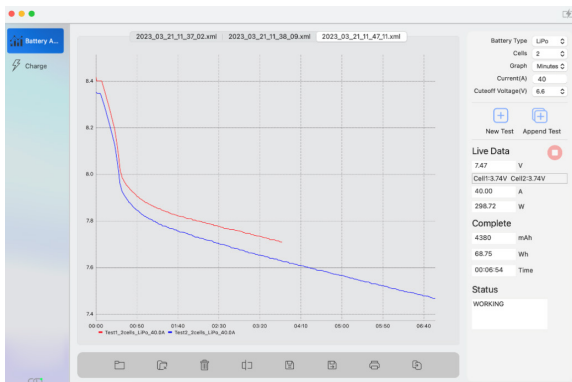

App Control with SkyRC

This charger comes equipped with a built-in Bluetooth 5.0 module, enabling users to easily control the charger and analyze battery performance via the SkyRC app. Whether you're racing outdoors or at home, you can conveniently test and monitor battery performance curves anytime, anywhere.

Scan the QR code below to download the SkyRC app.



[Scan or Click to Download](#)

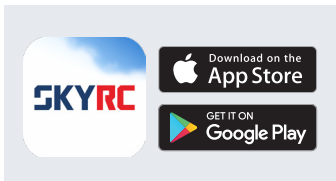

DC Power

1. On the main interface, hold the Scroll Button for five seconds to enter System Settings.
2. Select **DC Power** and adjust the output voltage and current.
3. Press the Scroll Button to activate the power function after setting.
4. Connect your desired DC device.



Scan or Click to Watch

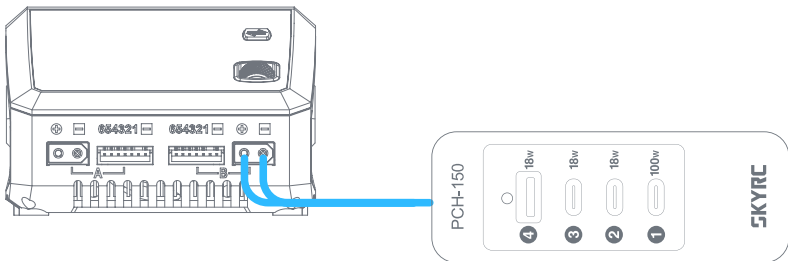

Note:

- On the DC Power interface, press the **Port** button to switch between Port A and Port B.
- From the main interface, press the **Scroll Button** to exit the DC Power function.
- On the DC Power interface, press the Port button to switch between Port A and Port B.
- The DC power function can be quickly activated in the Settings: port A is used for RC Tire Balancer, and port B is used for PCH-150 Power & Charging Hub.
*The RC Tire Balancer and the PCH-150 Power & Charging Hub are not included and must be purchased separately.

PD/QC3.0 Output

In addition to charging RC batteries, the charger can also charge mobile devices through the USB Type-C PD/QC3.0 output with a charging power of up to 20W.

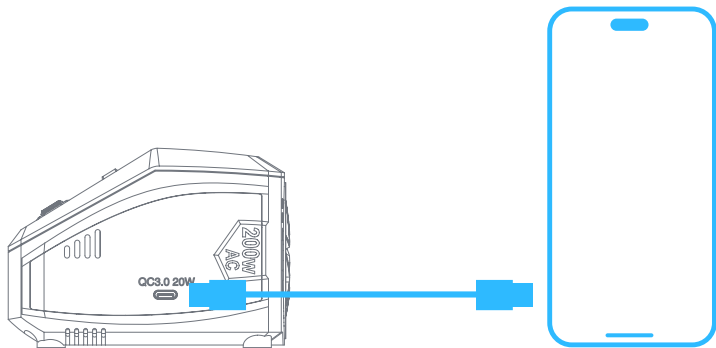

BumpGo with NFC Enabled

BumpGo is a technology developed by SkyRC that integrates NFC tags to revolutionize the charging process.

How to Use the BumpGo Tag on Batteries with D200neo+

BumpGo is a technology developed by SkyRC that integrates NFC tags to revolutionize the charging process.



Scan or Click to Watch

Step 1:

New BumpGO Tag Found.
Please Configure the Tag
and Save it.

Next

Back

Tap a new BumpGo tag onto the sensing area of the charger. A menu will appear; click Next to proceed to the battery task window.

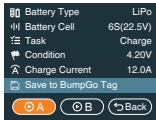
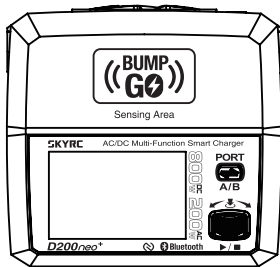

Step 2:

Set the desired parameters: battery type, the number of cells, charge or discharge, condition, cycle, and charge current. Use the scroll button to navigate to Save to BumpGo Tag and press to confirm.

Step 3:

The tag has been
successfully written

Back

A menu will appear instructing you to tap the BumpGo tag near the charger's sensing area. Hold the tag near the sensing area until you see "The tag has been successfully written."

BumpGo with NFC Enabled

How to Charge with the BumpGo tag?



Scan or Click to Watch

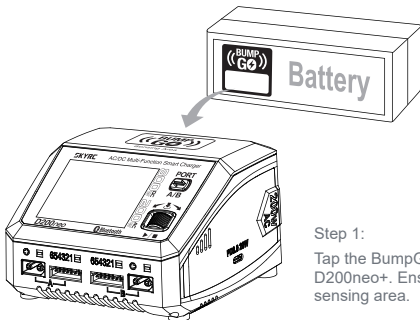

Step 1:

Tap the BumpGo tag on the battery onto the sensing area of the D200neo+. Ensure the tag is in good contact with the charger's sensing area.

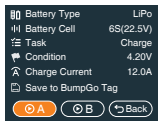

Step 2:

A menu will appear, displaying all the parameters stored in the tag.

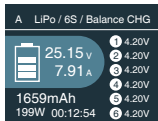

Step 3:

Select Port A or B, then press the Scroll Button to begin charging. Say goodbye to the hassle of manually adjusting parameters.

Note:

This feature is only available for the D200neo+ NFC version.

Firmware Upgrade



Scan or Click to Watch

Method 1

1. Open the **SkyCharge** app.
2. Tap "+" to add the device, verify the corresponding Bluetooth number, and connect to D200neo.
3. Enter the Settings page, when the SkyCharge app detects a new firmware, choose to upgrade.
4. Wait for the progress bar to reach 100%. The process will take approximately 5 minutes.



 **Bluetooth**

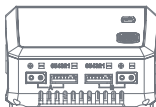

Method 2

1. Connect D200neo to your computer using a USB Type-C cable.
2. Launch **Charger Master** on your computer.
3. Once the status shows **CONNECTED**, click to check for new firmware.
4. If a new firmware is detected, click **Upgrade**.
5. Wait for the progress bar to reach 100%. The process will take approximately 5 minutes.

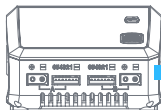









Errors Explained

In the event of a fault, D200neo will display an error message indicating issues such as connection problems or battery mismatches. Refer to the table below for troubleshooting solutions based on the error code.

Error Message	Explanation
DC Input Low!	DC input voltage is lower than preset!
DC Input High!	DC input voltage is higher than preset!
Battery Error!	The battery is broken or not detected!
Cell Error!	The cells do not match!
Battery Type Error!	The battery type is wrong!
Overcharge!	The battery is overcharged!
Over Time!	The program is timed out!
Internal Temp. Too High!	he internal temperature is high!
Over Load!	The charger is overloaded!
Reversed Polarity!	The battery connection is reversed!
Fully Charged!	The battery is fully charged already!
Outlet Overload!	The output is overloaded!
Balance Connection Break!	The balance connection is incorrect!
Cell Volt Diff.!	The voltage difference between each cell is high!
AC to DC Too Low!	The input voltage is too low!
Power Setting Error!	The DC power setting is incorrect!















Charge Settings

On the main interface, press the Scroll Button to enter Charge Settings, where you can switch between Ports A and B by pressing the Port button.













Menu	Definition
 Battery Type	Select your desired battery type. (LiPO, Lilon, LiFe, LiHV, Pb, NiMH, NiCd)
 Battery Cell	Select the number of battery cells corresponding to the battery type. (Li-xx: 1-6S, Ni-xx: 4-15S, Pb: 3S/6S/12S)
 Task	Select the program to be performed. (Balance CHG, Charge, Storage, Discharge, Parallel, etc.)
 Condition	Set the cut-off voltage as per the task.
 Current	Set the charge or discharge current.
 Cycle	Set the cycle count.
 Start	Start the current program.
 Back	Back to the main interface.

System Settings

On the main interface, hold the Start button for five seconds to enter System Settings.

Menu	Option	Definition
 Task Parameters	 Safety Timer	Customize a period for program protection.
	 Max.Capacity	Customize the protection of capacity.
	 Trickle Charge	Enable/disable trickle charge.
	 Back	Back to the previous interface.
 System Settings	 Language	Select your desired system language.
	 Max.Input Power	The maximum charge power. AC Input: 200W DC Input: 800W
	 Min.Input Voltage	In DC Input, set the minimum voltage for input protection.
	 LCD BackLight	Adjust the brightness of the screen.
	 Volume	Adjust the volume of the key and beep.
	 Completion Signal	Choose the way you'd like to be reminded when the program completes.
	 USB	Select the function of the USB Type-C port Auto: the charger detect the input of the USB port automatically Data: connect to PC Charge: charge the mobile devices
	 Back	Back to the previous interface.

System Settings

Menu	Option	Definition
 DC Power (Press the port button to switch between port A/B)	 Voltage	Set the output voltage. (5.0-27.0V)
	 Current	Set the output current. (1.0-15.0V)
	 Start	Enable DC power output and return to the main interface.
	 Back	Back to the previous interface.
 Power for Tire Warmer- A	N/A	Activate to power SkyRC Tire Warmer on port A
 Power for PD Hub - B	N/A	Activate to power SkyRC PD Hub on Port B
 Battery Meter	N/A	Measure the battery voltage and internal resistance. (Switch A/B ports by pressing the Port button.)
 System Self-checking	N/A	N/A
 Factory Settings	N/A	Restore to the factory settings.
 System Info	N/A	Check the current system status.
 System Upgrade	N/A	Upgrade the system.
 Back	N/A	Back to the previous interface.

In The Box

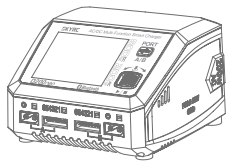

1* SkyRC D200neo Charger

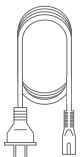

1* AC Power Cord



1* Quick Start Guide

Optional Parts

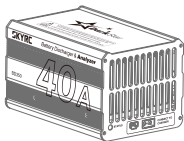

BD350 Discharger
(SK-600147-01)



BD380 Discharger
(SK-600153-01)



Parallel Charging Cable
(SK-600023-19)

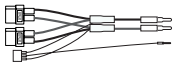

Pro Parallel Charging Cable
(SK-600023-20)



PCH-150 Charging Hub
(SK-600148-01)

Conformity Declaration

D200neo satisfies all relevant and mandatory CE directives and FCC Part 15 Subpart B.

Test Standards	Title	Result
EN 60335-1	Household and similar electrical appliances - Safety - Part 1: General requirements.	Conform
EN 60335-2-29	Household and similar electrical appliances – Safety – Part 2-29: Particular requirements for battery chargers.	Conform
EN 55014-1	Electromagnetic compatibility – Requirements for household appliances, electric tools and similar apparatus - Part 1: Emission.	Conform
EN 55014-2	Electromagnetic compatibility – Requirements for household appliances, electric tools and similar apparatus – Part 2: Immunity Product Family Standard.	Conform
EN 61000-3-2	Electromagnetic compatibility (EMC) – Part 3-2: – Limits for harmonic current emissions (equipment input current up to and including 16 A per phase)	Conform
EN 61000-3-3	Electromagnetic compatibility (EMC) - Part 3-3: Limitation of voltage supply systems for equipment with rated current ≤ 16 A.	Conform
FCC Part	The program is timed out!	
Subpart 15B	Title 47 Telecommunication Part 15 - RADIO FREQUENCY DEVICES Subpart B - Unintentional Radiators.	Conform
EN 300328	Electromagnetic compatibility and Radio spectrum Matters (ERM); Wideband transmission systems; Data transmission equipment operating in the 2.4 GHz ISM band and using wide band modulation techniques; Harmonized EN covering essential requirements under article 3.2 of the R&TTE Directive.	Conform
EN 301489-1	The battery connection is reversed!	
EN 301489-17	Electromagnetic compatibility and Radio spectrum Matters (ERM); ElectroMagnetic Compatibility (EMC) standard for radio equipment and services; Part 1: Common technical requirements. Part 17: Specific conditions for Broadband Data Transmission Systems.	Conform
EN 50663: 2017	Generic standard for assessment of low power electronic and electrical equipment related to human exposure restrictions for electromagnetic fields (10 MHz - 300 GHz)	Conform
EN 62479	assessment of the compliance of low power electronic and electrical equipment with the basic restrictions related to human exposure to electromagnetic fields (10 MHz to 300 GHz)	Conform
EN 61558-2-16 EN 61558-1	Safety of transformers, reactors, power supply units and similar products for supply voltages up to 1 100 V - Part 2-16: Particular requirements and tests for switch mode power supply units and transformers for switch mode power supply units	Conform
Part 15 Section 15.247	Operation within the bands 902 - 928 MHz, 2400 - 2483.5 MHz, and 5725 - 5850 MHz.	Conform

Warranty and Service

Liability Exclusion

This charger is designed and approved exclusively for use with the types of battery stated in this Instruction Manual. SkyRC accepts no liability of any kind if the charger is used for any purpose other than that stated. We are unable to ensure that you follow the instructions supplied with the charger, and we have no control over the methods you employ for using, operating, and maintaining the device. For this reason, we are obliged to deny all liability for loss, damage, or costs that are incurred due to the incompetent or incorrect use and operation of our products, or which are connected with such operation in any way. Unless otherwise prescribed by law, our obligation to pay compensation, regardless of the legal argument employed, is limited to the invoice value of those SkyRC products which were immediately and directly involved in the event in which the damage occurred.

Warranty and Service

We guarantee this product to be free of manufacturing and assembly defects for a period of one year from the time of purchase. The warranty only applies to material or operational defects, which are present at the time of purchase. During that period, we will repair or replace free of service charge for products deemed defective due to those causes.

This warranty is not valid for any damage or subsequent damage arising as a result of misuse, modification, or as a result of failure to observe the procedures outlined in this manual.

Note:

1. The warranty service is valid in China only.
2. If you need warranty service overseas, please contact your dealer in the first instance, who is responsible for processing guarantee claims overseas. Due to high shipping costs, and complicated custom clearance procedures to send back to China, please understand that SkyRC can't provide warranty service to overseas end users directly.
3. If you have any questions which are not mentioned in the manual, please feel free to send an email to info@skyrc.com

SKYRC

The content is subject to change without notice;
please refer to our website for the latest version!



<https://www.skyrc.com>

If you have any questions about this document, please contact SkyRC by sending a message to **support@skyrc.com**

SKYRC ® is a trademark of SkyRC Technology Co., Ltd.

© 2026 SkyRC Technology Co., Ltd.